

REV	REV DATE	DESCRIPTION
-----	----------	-------------

X GÖRÜNÜŞÜ

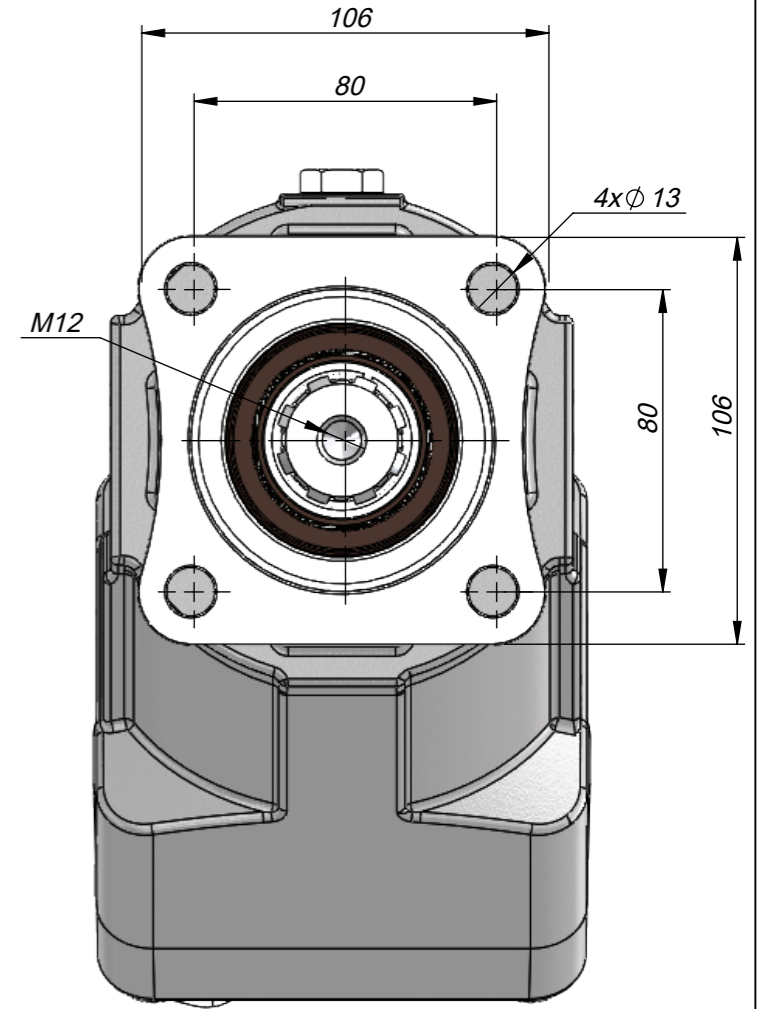
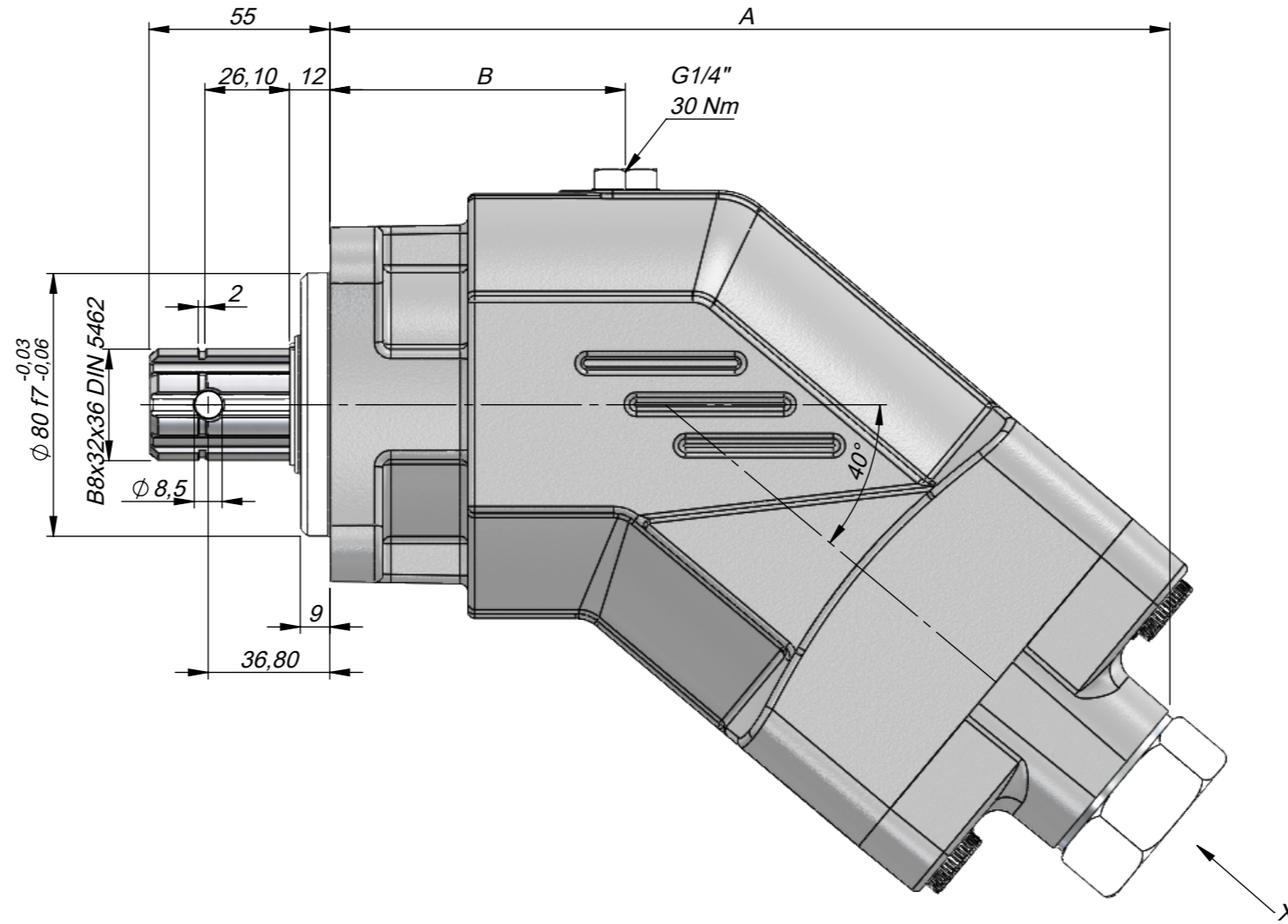
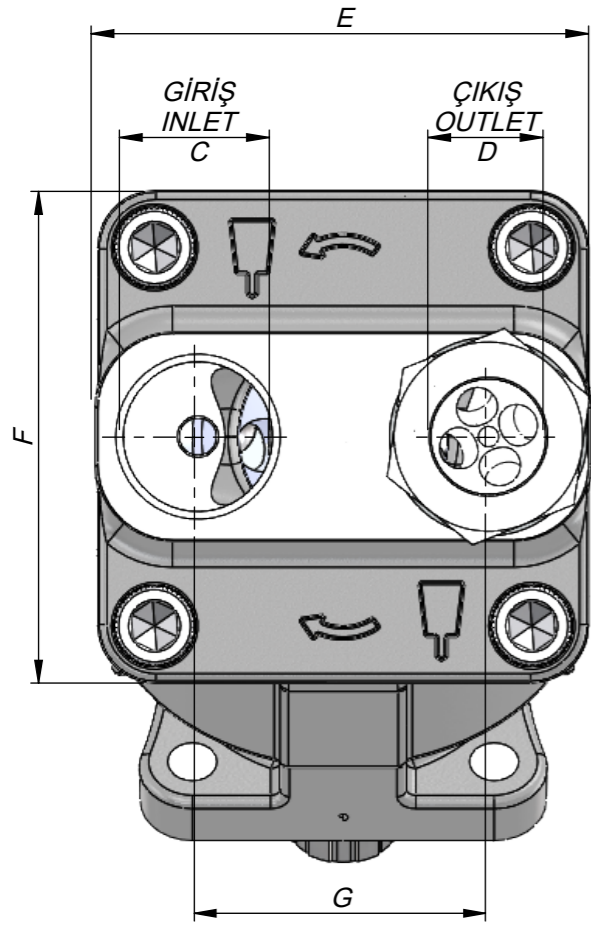

Kod / Code	İletişim Hacmi Displacement (Cm <sup>3</sup> /rev)	Max.Sürekli Basiç Max.Continuous Pressure	Maks.Anlık Basiç Max.Peak pressure	Maks. Hız Max. speed (RPM)		A (mm)	B (mm)	C (inch)	D (inch)	E (mm)	F (mm)	G (mm)			
				nom	max										
AP023SF111 AP023SF121	23	350	400	3050	4300	180	58	G3/4"	G1/2"	89	89	52			
AP032SF111 AP032SF121	32			2750	3900										
AP045SF111 AP045SF121	45			2650	3800	210	78	G1"	G3/4"	110,5	108	64			
AP056SF111 AP056SF121	56			2550	3700	218	80								
AP063SF111 AP063SF121	63			2200	3200										
AP080SF111 AP080SF121	80			250	300	2150	3100	245	94	G1 1/4"	G1"	127	118	69	
AP107SF111 AP107SF121	107					2000	2800	255							131,6
AP125SF111 AP125SF121	125	1750	2500			131,6	130								

Tapaların Sıkma Torku Tightening Torque Of The Plugs	
G1/2"	55-65Nm
G3/4"	90-100Nm
G1"	135-160Nm
G1 1/4"	200-230Nm

	NAME-SURNAME	DATE	SİGNATURE
DRAWER	A.AKGÖZ	18.01.2019	
CONTROL	D.POLAT	18.01.2019	
APPROVAL	M.KAZEL	18.01.2019	
SCALE	1:2	PRODUCT NAME:ISO FEYZ PISTON PUMP	



\*(1) - Left- Sol (2) - Right- Sağ