

TEKNİK VERİLER | TECHNICAL DATA

2+4 DELİKLİ SAE B 13 DİŞ ÇİFT YÖNLÜ DİŞLİ MOTOR
2+4 HOLES SAE B 13 TEETH BI-DIRECTIONAL GEAR MOTOR

Giriş Basıncı Inlet Pressure		0.3÷ 2 bar	
Çalışma Viskozite Seviyesi Operating Viscosity Range		-12:100 cSt	
Sıvı Sıcaklığı Fluid Temperature		-40 °C+145 °C	
Çalışma Basıncı Working Pressure	Kirlilik Contamination		Filtre Filter
	NAS 1638	ISO 4406	$\beta_x=75$
≥ 200 bar	11	20/17	25 μm
≤ 200 bar	12	21/18	40 μm

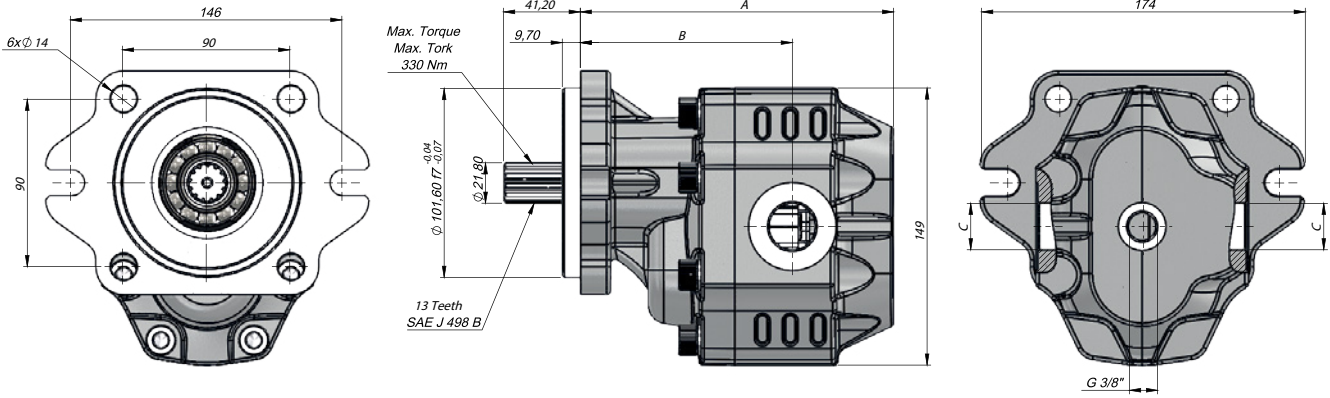

Kod Code	İletim Hacmi Displacement	Maks.Sürekli Basınç Max.Continuous Pressure	Min. Hız Min.Speed	Maks.Sürekli Hız Max.Continuous Speed	A	B	Giriş Inlet	Çıkış Outlet
BD	(cm ³ /rev)	(100%)(BAR)	(RPM)	(RPM)	(mm)	(mm)	C	C
GM30017BF531	17	300	300	2500	150	103	G1/2"	G1/2"
GM30027BF531	27	290			156	108		
GM30034BF531	34	285			161	109		
GM30043BF531	43	280		2000	167	114	G3/4"	G3/4"
GM30051BF531	51	230						
GM30061BF531	61	225						
GM30073BF531	73	215		1600	192,5	122,5	G1"	G1"
GM30082BF531	82	200						
GM30100BF531	100	190						
GM30125BF531	125	170	1500	204	138,5	G1 1/4"	G1 1/4"	
								220