

TEKNİK VERİLER | TECHNICAL DATA

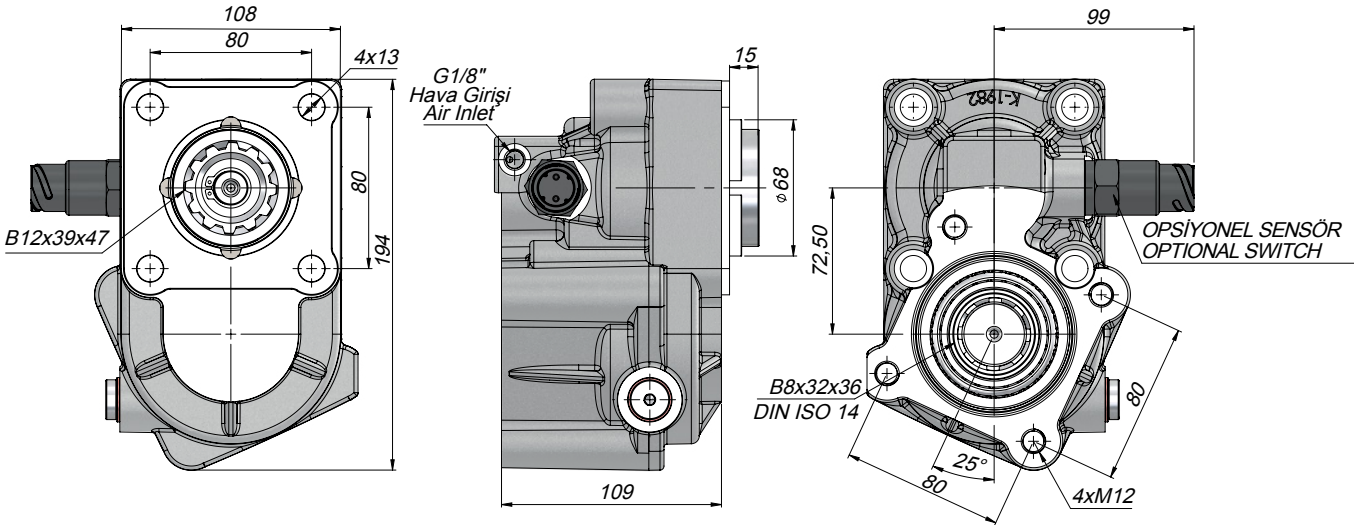

Şanzıman No / Gearbox No
 ZF16S251-221-151-150-130,ZFS5/
 AK/6S-120-111-110-92,GPZFS5/AK/6S-90
 80-70-66-65-55-50 42-36-35/ ZF 9S 75/
 9S109/16S109/ ZF AK 680/AK 690/S680/S690



POWER TAKE
OFFS

Kod Code	Havalı Çalışma Basıncı Pneumatical Working Pressure	Kontrol Sistemi Control System	Çevrim Oranı Ratio	Çıkış Tork Outlet Torque		Güç Power		Çıkış Hızı Output Speed (dev/dak)	Dönüş Yönü Direction Of Rotation
	(Bar)			(Kçm)	(Nm)	(Kw) 1000 dev/dak			
PT2VCS153SW	7-12	Havalı Pneumatic	1,53	40	400	28.2 Hp	20.7 Kw	700	Sol Left
PT2VCS153WS									

*(SW) - Switch
 (WS) - Without Switch