

TEKNİK VERİLER | TECHNICAL DATA

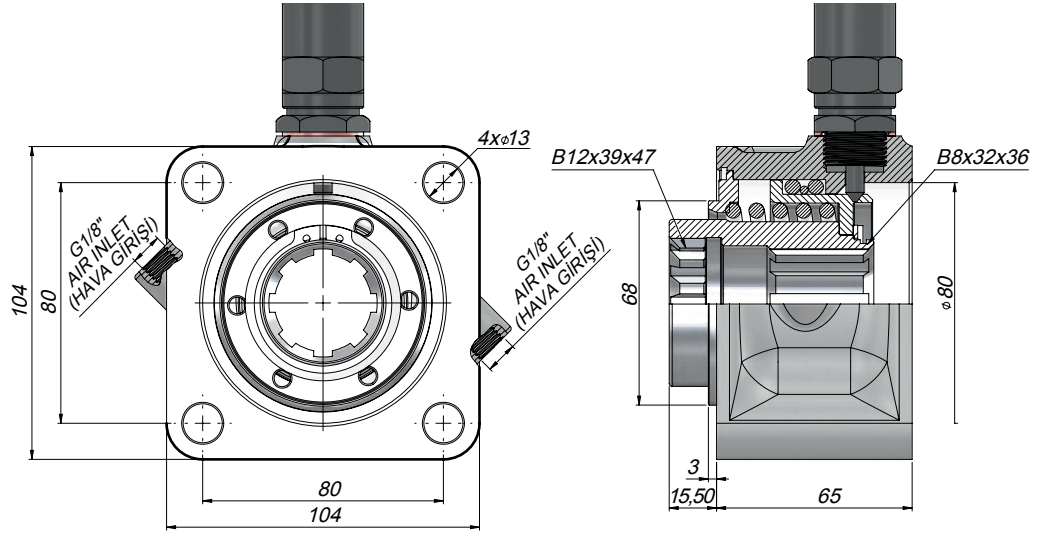

Kod Code	Şanzuman Modeli Gear Box Model	Havalı Çalışma Basıncı Pneumatical Working Pressure	Kontrol Sistemi Control System	Çıkış Tork Outlet Torque	Güç Power	Çıkış Hızı Output Speed
		(Bar)		(Kçgm) (Nm)	(Kw) 1000 dev/dak	(dev/dak)
PT1ZFAS12SW	16S-130-160-190	7-12	Havalı Pneumatic	57	35 Hp 25.7 Kw	500

* (SW) - Switch

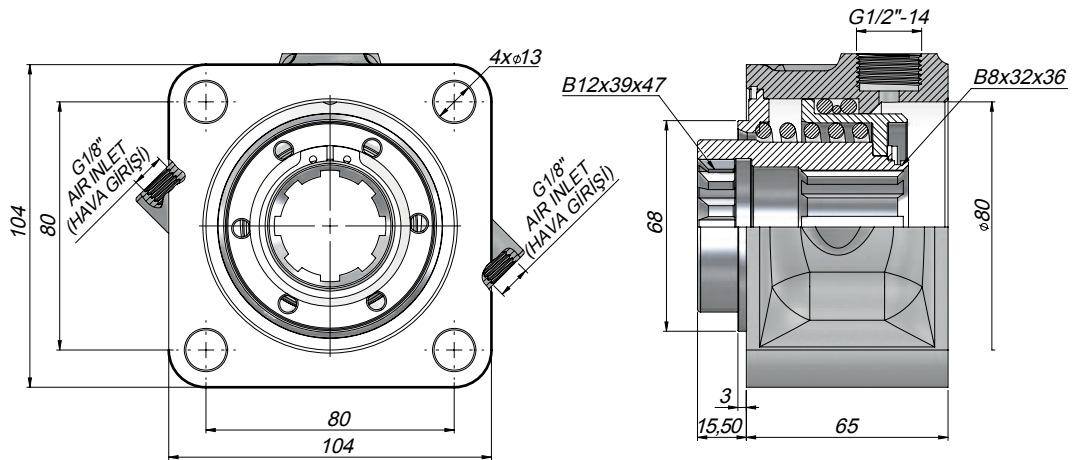

Kod Code	Şanzuman Modeli Gear Box Model	Havalı Çalışma Basıncı Pneumatical Working Pressure	Kontrol Sistemi Control System	Çıkış Tork Outlet Torque	Güç Power	Çıkış Hızı Output Speed
		(Bar)		(Kçgm) (Nm)	(Kw) 1000 dev/dak	(dev/dak)
PT1ZFAS12	16S-130-160-190	7-12	Havalı Pneumatic	57	35 Hp 25.7 Kw	500