

TANDEM POMPA TANDEM PUMP KODLAMA SİSTEMİ | CODING SYSTEM

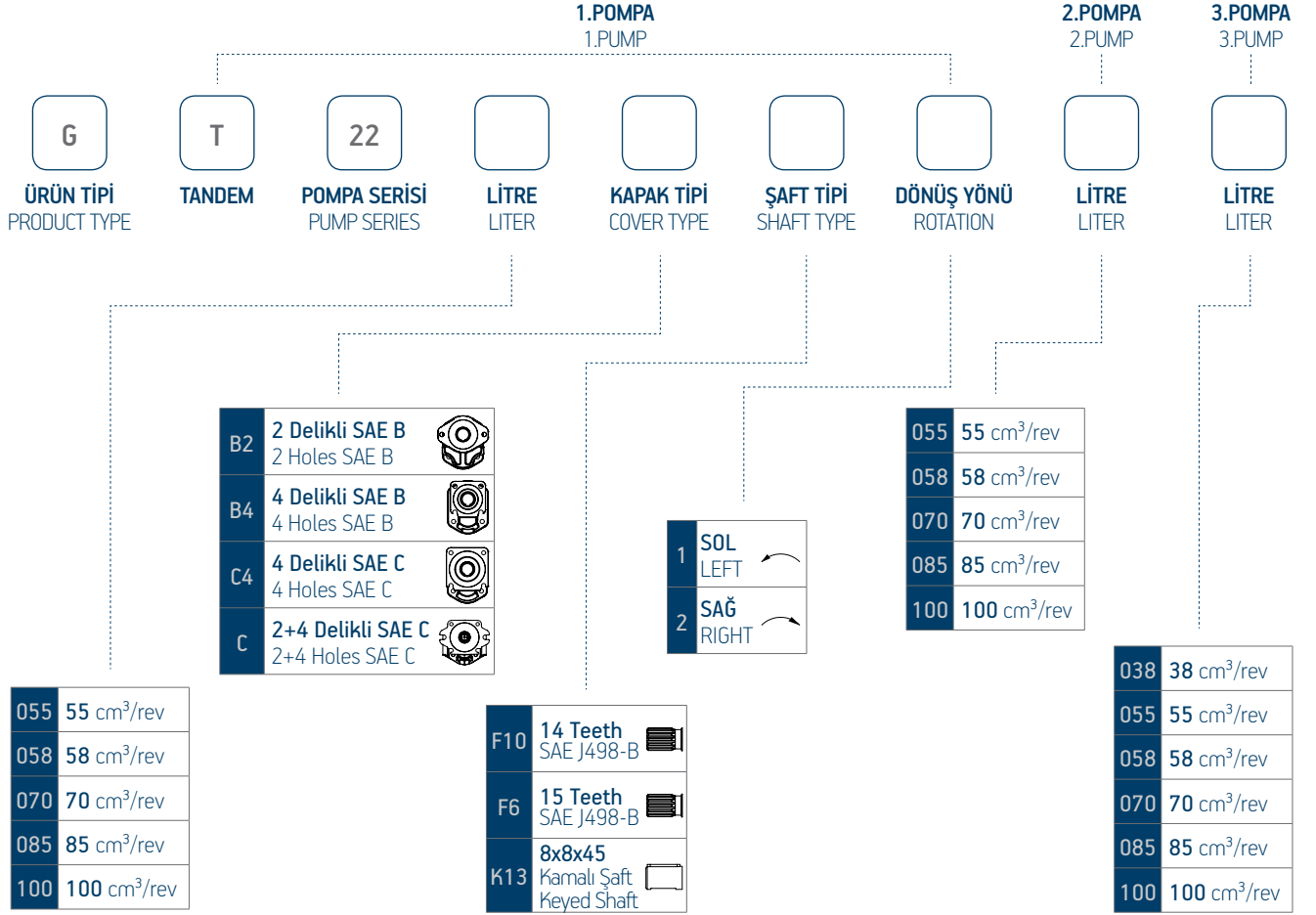

4 DELİKLİ SAE B TANDEM DİŞLİ POMPA | 4 HOLES SAE B TANDEM GEAR PUMP

Giriş Basıncı Inlet Pressure		0.3÷ 2 bar	
Çalışma Viskozite Seviyesi Operating Viscosity Range		-12:100 cSt	
Sıvı Sıcaklığı Fluid Temperature		-40 °C+145 °C	
Çalışma Basıncı Working Pressure	Kirlilik Contamination		Filtre Filter
	NAS 1638	ISO 4406	$\beta_x=75$
≥200 bar	11	20/17	25 µm
≤200 bar	12	21/18	40 µm

AKSA-NEVİ-AKVA
GEAR PUMP

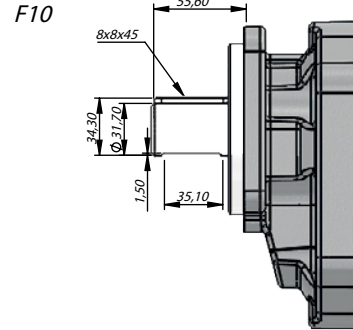
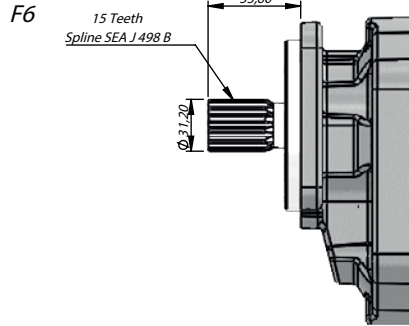
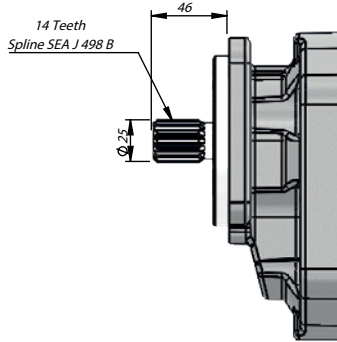

K13

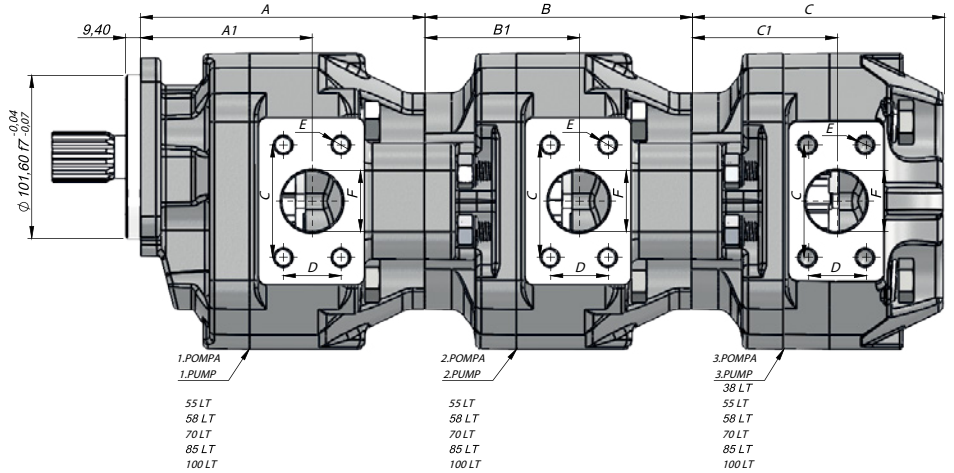
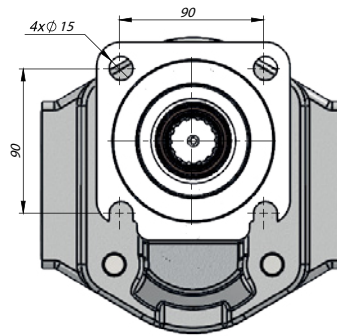

İletim Hacmi Displacement	Maks.Sürekli Basınç Max.Continuous Pressure	Min. Hız Min. Speed	Maks.Sürekli Hız Max.Continuous Speed	Giriş Inlet										Çıkış Outlet						
				A	A1	B	B1	C	C1	C	D	E	F	C	D	E	F			
(cm ³ /rev)	(100%)(BAR)	(RPM)	(RPM)	mm	mm	mm	mm	mm	mm	mm	mm	mm	mm	mm	mm	mm	mm	mm	mm	
38	310	500	3000	-	-	-	-					52,50	26	M10	25,4	47,60	22		19	
55				177,5	106	167	95,5	157,5	90,5											
58	290			70	36	M12	38	58,50	30	M10	32									
70	245			178,5	108	168	97,5													
85	200			187,5	113,5	177	103	168,5	100											
100	180			193,5	116,5	183	106	174,5	106	78	43		51							